

EXT-USBC2XI-100M

2-Port USB 3.2 Extender (100m)

Dual USB-C & USB-B Host Inputs with Auto/Manual Switching, FSYNC GPIO & RS-232 over CAT6a

Surge Protection Recommended — This product contains sensitive electronic components. Use of surge protection is highly recommended in all installations.

TABLE OF CONTENTS

1. Features	1
2. Package Contents	1
3. Specifications	2
4. Operation Controls	3
4.1 Transmitter Panel	3
4.2 Receiver Panel	3
5. API Commands	4
6. Application Example	5
7. Troubleshooting	6

FEATURES

- ✓ Extends USB 3.2 at 5Gbps up to 100m/328ft over a single CAT6a (F/FTP) cable with hardware-accelerated USB signal transmission
- ✓ Selectable TX host inputs: 1× USB-C and 1× USB-B with auto-switching (5V detection) and manual switching modes
- ✓ RX device ports: 1× USB-C and 3× USB-A; TX device ports: 1× USB-C and 2× USB-A for local peripheral access
- ✓ FSYNC GPIO pass-through for precise industrial camera frame synchronization — default 0–5V signal level
- ✓ RS-232 pass-through and full ASCII API control via serial or USB-C service port (baud configurable 4800–115200)
- ✓ Bi-directional 24V PoC — power either TX or RX; the other end is powered over the CAT6a cable
- ✓ Backwards compatible with USB 2.0 and USB 1.1; plug-and-play, no drivers required on any OS
- ✓ Firmware upgradeable via USB-C service port; RS-232 and FSYNC signals pass through TX–RX in both directions

PACKAGE CONTENTS

1× USB 3.2 Extender — Transmitter (TX) • 1× USB 3.2 Extender — Receiver (RX) • 1× 24V/3.75A Locking Power Supply • 2× 4-pin 3.5mm Phoenix Connector (Male) • 4× Mounting Ear • 8× Machine Screw (KM3×4) • 1× User Manual



Specifications

TECHNICAL

USB Protocol	USB 3.2 Gen 1
Transmission Rate	Up to 5Gbps
Transmission Distance	100m / 328ft over CAT6a (F/FTP) cable 1.5m / 4.9ft over USB cable
ESD Protection	IEC 61000-4-2: ±8kV (air-gap discharge) & ±4kV (contact discharge)

TRANSMITTER CONNECTIONS

Host Inputs	1× HOST 1 [USB Type-C, 24-pin female] 1× HOST 2 [USB Type-B, 9-pin female]
Device Outputs	1× USB-C DEVICE [USB Type-C, 24-pin female, 5V/1A] 2× USB-A DEVICE [USB Type-A, 9-pin female, 5V/1A]
Link	1× HDBT-USB3 [RJ45, 24V PoC]
Control	1× RS-232 [3-pin 3.5mm phoenix] 1× FSYNC [1-pin 3.5mm phoenix] 1× SERVICE [USB Type-C, firmware update]

RECEIVER CONNECTIONS

Link	1× HDBT-USB3 [RJ45, 24V PoC]
Device Outputs	1× USB-C DEVICE [USB Type-C, 24-pin female, 5V/1A] 2× USB-A DEVICE [USB Type-A, 5V/1.5A] 1× USB-A DEVICE [USB Type-A, 5V/1A]
Control	1× RS-232 [3-pin 3.5mm phoenix] 1× FSYNC [1-pin 3.5mm phoenix] 1× SERVICE [USB Type-C, firmware update]

MECHANICAL

Housing	Metal Enclosure, Black
Dimensions	140mm (W) × 75mm (D) × 23mm (H) — TX and RX identical
Weight	Transmitter: 313g Receiver: 318g

POWER

Power Supply	DC 24V / 3.75A (multinational locking adapter)
Input Voltage	AC 100–240V, 50/60Hz
Power Consumption	Transmitter: 23W (max) Receiver: 35W (max) Combined: 68W (max)

ENVIRONMENTAL

Operating Temp	32–104°F / 0–40°C
Storage Temp	–4–140°F / –20–60°C
Operating Humidity	20–80% RH (non-condensing)
Storage Humidity	10–90% RH (non-condensing)



Operation Controls

4.1 TRANSMITTER PANEL

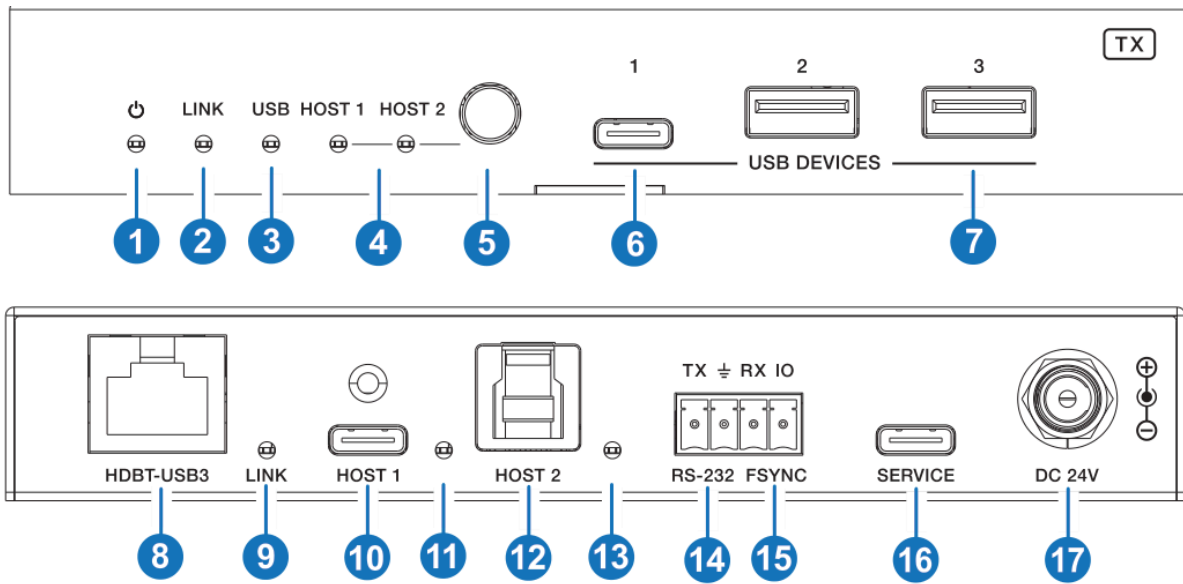

NO.	NAME	FUNCTION DESCRIPTION
1	Power LED	Illuminates when the transmitter is powered on.
2	LINK LED	Solid: TX and RX are linked over CAT6a. Off: link not established.
3	USB LED	Solid: USB 3.0 signal active. Blinking: USB 2.0 detected. Off: no USB signal.
4	HOST LED (1/2)	Indicates which host input is currently selected — HOST 1 (USB-C) or HOST 2 (USB-B).
5	Host Switch Button	Press to toggle between HOST 1 (USB-C) and HOST 2 (USB-B). Hold 3s to toggle auto-switch mode.
6	USB DEVICE (C)	USB-C downlink device port for local peripherals. Output: 5V/1A.
7	USB DEVICE (A×2)	USB-A downlink device ports for local peripherals. Output: 5V/1A each.
8	HDBT-USB3	RJ45 link port. Connect to RX HDBT-USB3 via CAT6a (F/FTP) cable.
9	HOST 1 (USB-C)	Uplink USB-C host input. Connect to USB-C PC or controller. Also used as HUB firmware update port.
10	HOST 2 (USB-B)	Uplink USB-B host input. Connect to USB-B PC or legacy control system.
11	RS-232	3-pin 3.5mm phoenix connector for RS-232 pass-through and API command control.
12	FSYNC	Frame sync GPIO pass-through (TX → RX) for industrial camera synchronization. Default: 0–5V.
13	SERVICE	USB-C firmware update port (USB 2.0). Also used for API commands at 115200 bps fixed.
14	DC 24V	24V/3.75A locking power input. PoC powers RX if RX is unpowered.

4.2 RECEIVER PANEL

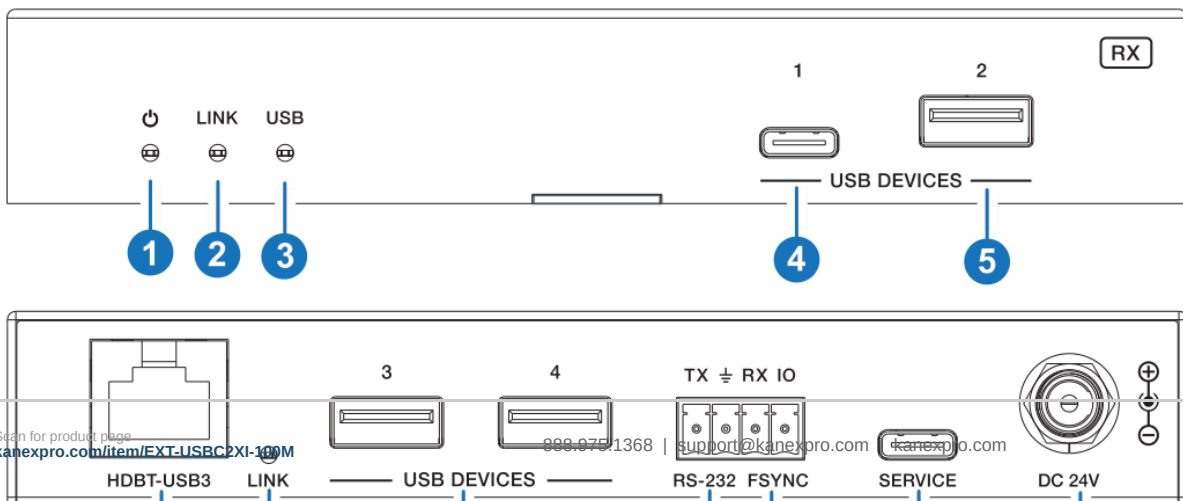

API Commands

Connect the SERVICE (USB-C) or RS-232 (3-pin phoenix) port to a PC and open a serial terminal. **SERVICE port:** 115200 bps fixed. **RS-232 port:** 4800–115200 bps configurable (default 115200). Data: 8, Stop: 1, Parity: none. End mark: <CR><LF>.

COMMAND	FUNCTION	EXAMPLE	DEFAULT
?	List all commands	?	
get fw version	Get firmware version	get fw version	
set reboot	Reboot the device	set reboot	
set reset	Factory reset (requires "Yes" confirmation)	set reset	
get status	Full system status report	get status	
set key on/off	Lock / unlock front panel button	set key off	on
set baud x	RS-232 baud rate (1=4800, 2=9600, 3=19200, 4=38400, 5=57600, 6=115200)	set baud 6	115200
get baud	Get current RS-232 baud rate	get baud	
set input x	Select host input (x=1: USB-C HOST 1, x=2: USB-B HOST 2)	set input 1	1
get input	Get active host input	get input	
get usb5v x	Get USB host 5V status (x=0: all, x=1: HOST 1, x=2: HOST 2)	get usb5v 0	
set autoswitch x	Enable / disable auto host switching via 5V detection (x=On/Off)	set autoswitch on	on
get autoswitch	Get auto-switching status	get autoswitch	
set tx usbd x power y	TX device port power (x=0–3 port, y=0:off / 1:follow host / 2:always on)	set tx usbd 0 power 1	1
set rx usbd x power y	RX device port power (x=0–4 port, y=0:off / 1:follow host / 2:always on)	set rx usbd 0 power 1	1
set hdbt update	Switch service port to HDBT UART for firmware update mode	set hdbt update	

RS-232 WIRING (3-PIN PHOENIX)

Pin 1: TX • **Pin 2:** GND • **Pin 3:** RX

FSYNC WIRING (1-PIN PHOENIX)

Single signal wire. Connect to master frame-sync source on TX; sync signal appears on RX phoenix output. Default signal level: 0–5V (configurable via firmware).



Application Example

DUAL-HOST USB 3.2 EXTENSION TO REMOTE PERIPHERAL SET OVER CAT6A

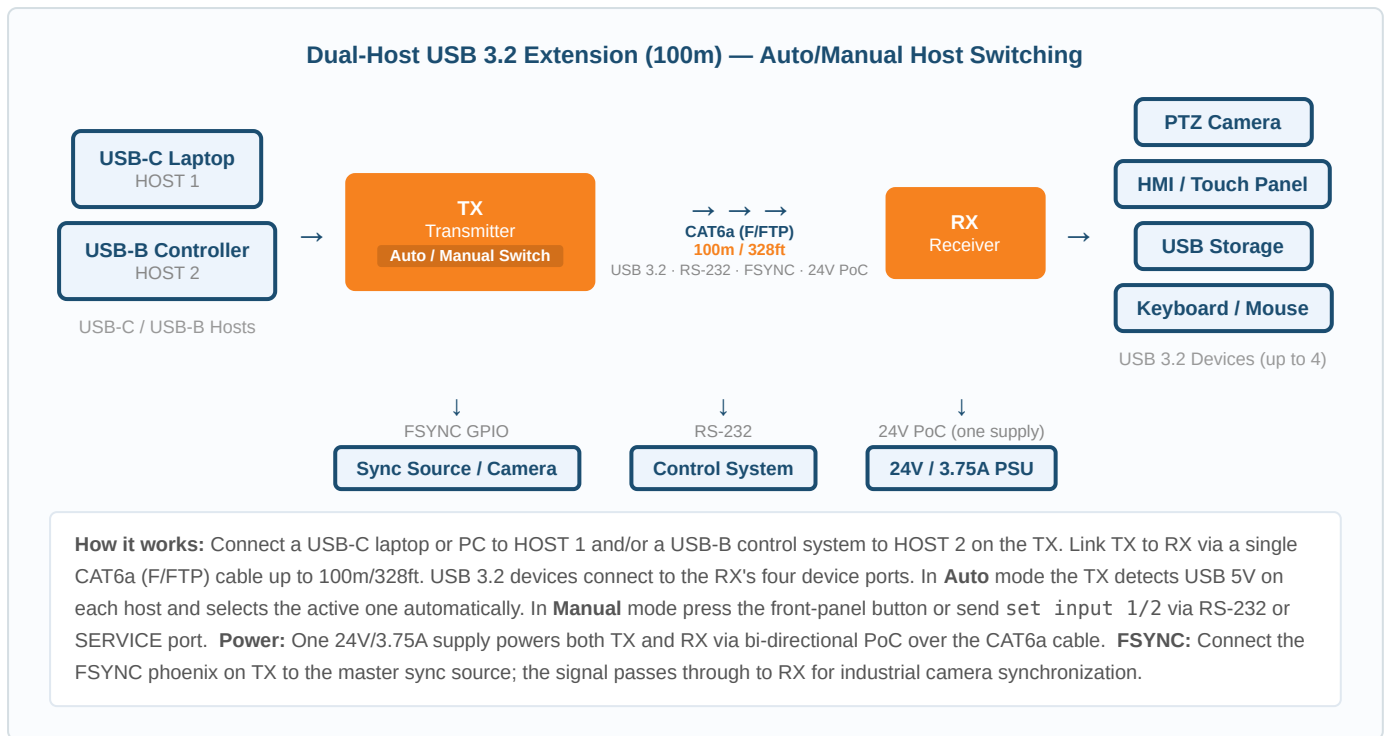

CONNECTION DIAGRAM

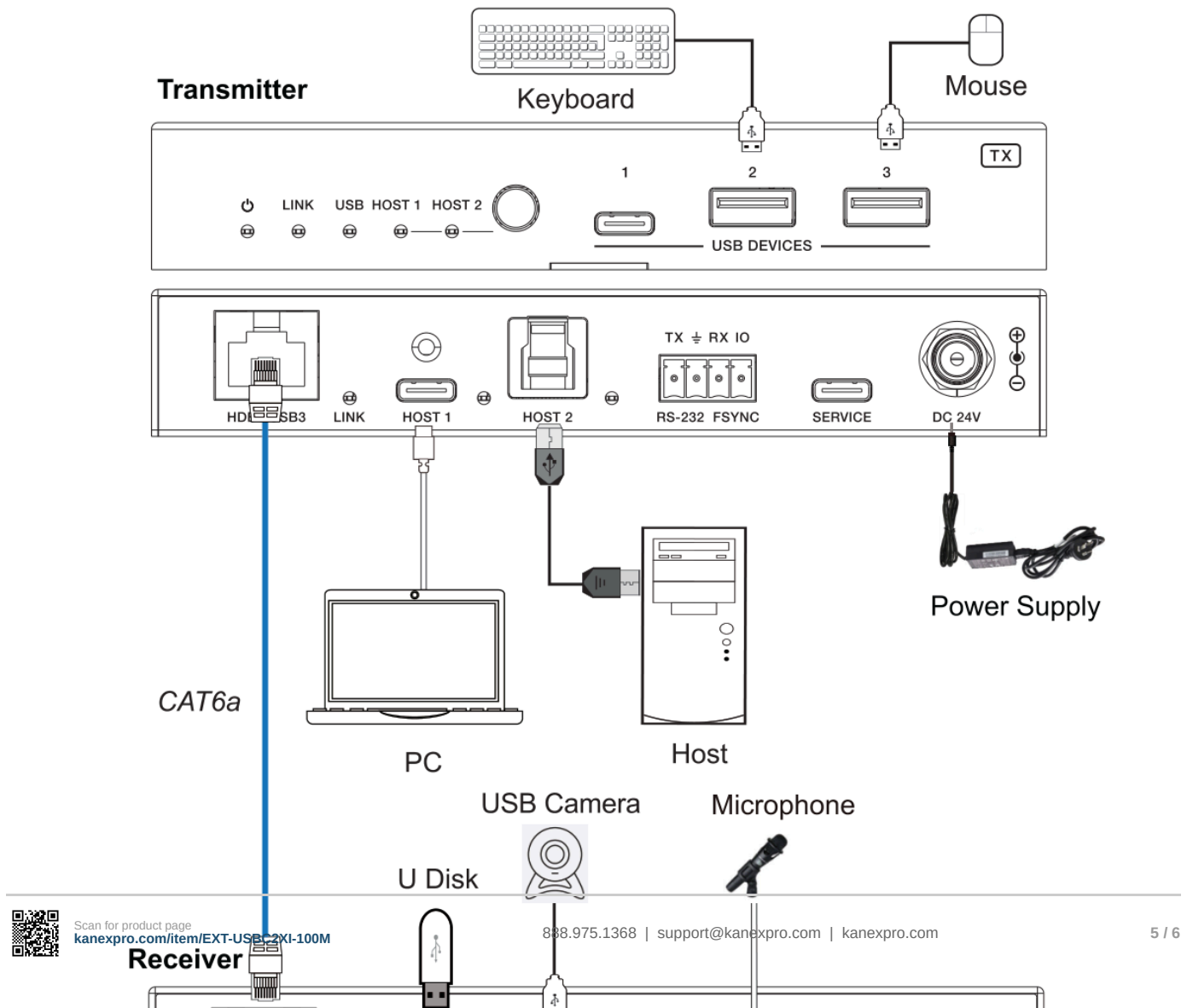

Troubleshooting

Q: No USB devices detected at the receiver end?

A: Confirm the CAT6a cable is connected to HDBT-USB3 on both TX and RX and the LINK LED is solid on both units. Verify USB 5V is present on the active host using `get usb5v 0`. Use direct point-to-point cable routing only — no network switches, patch panels, or couplers in the path.

Q: USB link falls back to USB 2.0 speed?

A: Confirm CAT6a F/FTP (shielded) cable is used — unshielded cable may degrade to USB 2.0 at 100m. Verify no couplers, coupler boxes, or patch panels are in the cable run. The USB LED blinks for USB 2.0 and is solid for USB 3.0.

Q: Auto-switching is not detecting my second host?

A: Auto-switching detects USB 5V on HOST 1 and HOST 2. Verify both hosts are powered on and USB cables are fully seated. Use `get usb5v 0` to check 5V on both ports. If needed, disable auto mode: send `set autoswitch off`, then `set input 1` or `set input 2` to lock the desired host.

Q: Some USB devices are not recognised at the receiver?

A: Check the device class is supported (HID, Mass Storage, Audio, Video Class, CDC). Verify the device does not exceed the per-port power budget (5V/1A on most ports, 5V/1.5A on two RX USB-A ports). High-power devices may require a self-powered USB hub at the RX end.

Q: FSYNC signal is not reaching the receiver?

A: Confirm the FSYNC source is wired to the 1-pin 3.5mm phoenix on the TX. Check the signal is within the 0–5V default range. Verify the LINK LED is solid on both TX and RX — FSYNC is only passed when the USB link is established.

Q: How do I update firmware?

A: Connect a USB-C cable from a PC to the SERVICE port on TX or RX. Send `set hdbt update` to switch to firmware update mode, then follow the firmware utility instructions. TX and RX firmware may be updated independently via their respective SERVICE ports.

Q: How do I access RS-232 API control?

A: Connect the 3-pin phoenix RS-232 port (TX / GND / RX) to a control system or USB-to-serial adapter. Open a terminal at 115200 bps (default), 8N1. Type `?` and press Enter to list all commands. Alternatively connect via the USB-C SERVICE port at 115200 bps fixed.

Q: Can I power both TX and RX from separate supplies?

A: No. The bi-directional PoC system is designed for one power supply only. Connect the included 24V/3.75A locking adapter to either the TX or the RX — do not connect power to both ends simultaneously.

